

USERS MANUAL

TABLE OF CONTENTS

1. PRODUCT DESCRIPTION	1
1.1 GENERAL	2
1.2 OVERVIEW OF THE RS485 AND RS422 PROTOCOLS	2
1.3 OPERATION	4
2. SPECIAL FEATURES	4
3. PANEL INDICATORS	5
3.1 FRONT PANEL	5
3.2 BACK PANEL	5
4. CONFIGURATION SETUP	6
4.1 DIPSWITCH CONTROLS	6
4.1.1 DIPSWITCH 1 & 2 CONFIGURATION	6
4.2 JUMPER SETTINGS	6
4.3 DATA CONNECTION (DB 15 CONNECTOR).	6
5. PREPARATION FOR USE	7
5.1 TYPICAL APPLICATIONS	7
5.1.1 RS485 2 wire configuration:	7
5.1.2 RS485 4 wire configuration:	8
6. PHYSICAL AND ELECTRICAL SPECIFICATION	10
6.1 ELECTRICAL	10
6.2 OPTICAL	10
6.3 FUNCTIONS AND CHARACTERISTICS	10
7. MODEL NUMBERS	11

1. PRODUCT DESCRIPTION

1.1 GENERAL

LL485 is a dual channel RS485 to fibre optic interface unit designed to extend either RS485 or RS422 data protocol over a fibre optic medium.

1.2 OVERVIEW OF THE RS485 AND RS422 PROTOCOLS

RS422 is a differential interface where signals are transmitted on a twisted pair from one transmitter to one or more receivers.

The signals are transmitted on two wires (twisted pair) and are either 0 volt or 5 volt. Let's name the two conductors in the twisted pair A and B. The signals on the conductors are differential levels. A logic '1' signal is transmitted as a 5 volt level in conductor A and a 0 volt level in conductor B, and a logic "0" is transmitted as a 0 volt level in conductor A and a 5 volt level in conductor B. The receiver extracts the signal from the twisted pair by analysing the differential signal arriving. The advantage is that electrical disturbances (like lightning induced pulse or electrical motor noise) will appear on both lines and because only the difference signal is used, the effect of the disturbance has little or no influence. A ground (0 volt) conductor is not necessary.

RS485 (sometimes called RS422 multidrop) is similar to RS422 as far as the signals (voltage levels) are concerned. The major difference is that the transmitter can be controlled to go into a high impedance condition where it is equivalent to not being connected to (having no influence on) the twisted pair. This allows multiple transmitters to be connected to the same twisted pair. By having intelligence in the stations controlling these transmitters they can send signals from various places on the same twisted pair. With RS422 the data is permanently driven on the lines and if a second transmitter is connected, a conflict will exist between the output levels of the transmitters. (Assume one transmitter tries to drive the line to a 5 volt level and another transmitter tries to drive the line to a 0 volt level, the line level will be undefined and the transmitters could be damaged if this situation exists permanently.)

The common RS485 configurations are two wire and four wire connections.

Two wire interface: (fig.1) One station is configured as the master in the system. The data moves backwards and forwards on the twisted pair. The data is half duplex (only moves in one direction at a any one time). This is sometimes called ping pong communications. The master would send data to the slave(s). The relevant slave(s) will then respond to the command/request from the master and send their data to the master. The time duration from the last bit of information moving in one direction before the response/data moves in the other direction is called the turnaround time of the dataline.

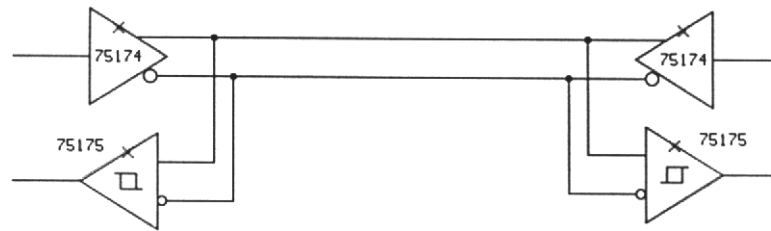

fig 1. RS485 Two wire point to point interface

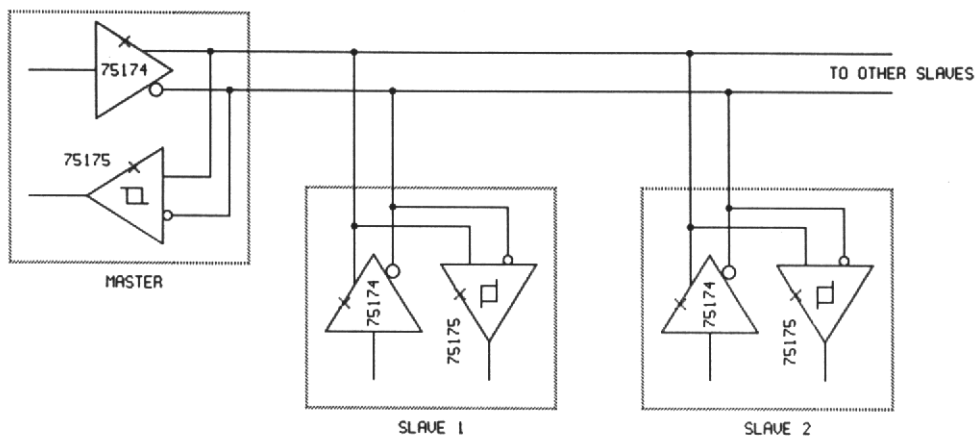

fig 2. RS485 Two wire multidrop interface

Four wire interface: (fig.2)The master transmit data to the slave station receivers on a twisted pair. The slaves all transmit on the second pair (at different times) and the master receives on this pair. The advantage is that if one slave station malfunctions and transmit permanently on the second pair, the master can still send data to the slaves.

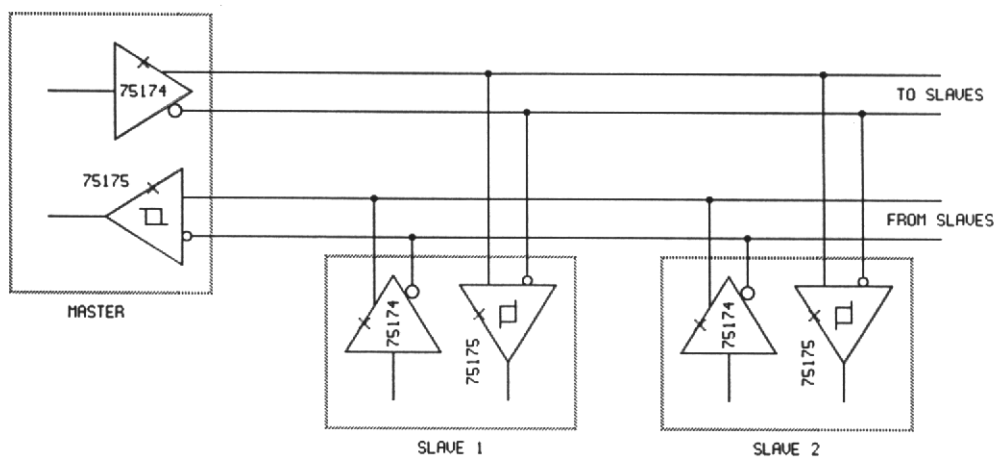

fig 3. RS485 Four wire multidrop interface

Additional benefits of converting to an optical fibre signal is:

1. Speed vs distance trade-off does not exist. Maximum speed, regardless of distance.
2. Electrical noise immune as glass does not pick up induced voltages.
3. Intrinsically safe.
4. Generates no electrical interference (emissions).

1.3 OPERATION

The LL485A unit consists of two RS485 line drivers in the same enclosure and can be used as two individual line drivers with no influence on each other.

The data received by the RS485 unit is converted to an optical signal. This is then sent across optical fibre to another RS485 unit where the signal is regenerated from the optical input and converted to the relevant electrical signal. The unit is totally transparent to the user protocol.

Turnaround time is the time from when a unit is transmitting until a unit can be receiving is less than 20us.

The units can be set to act as RS422 units (transmitter permanently driving on the copper interface, used in 4 wire applications).

2. SPECIAL FEATURES

1. The free standing RS485 line driver is housed in a metal case with rubber feet.
2. The power indication LED will always light up while there is power to the unit.
3. There are two dipswitches inside the unit to configure the unit.
4. The channel indicator LEDs on the front panel indicate the status on the optic fibre interfaces.
5. The input LED will light up when data is received on the DB15 connector.
6. The transmit LED will light up if data is output to the DB15 connector.
7. Both the relevant channel error LED will light up and the relevant channel relay contacts will close when no valid fibre optic signal is received from the remote unit.

3. PANEL INDICATORS

3.1 FRONT PANEL

The front panel contains from left to right the following :

- Power indication LED
- Channel 1 output indicator LED Channel 2 output indicator LED
- Channel 1 input indicator LED Channel 2 input indicator LED
- Channel 1 error indicator LED Channel 2 error indicator LED

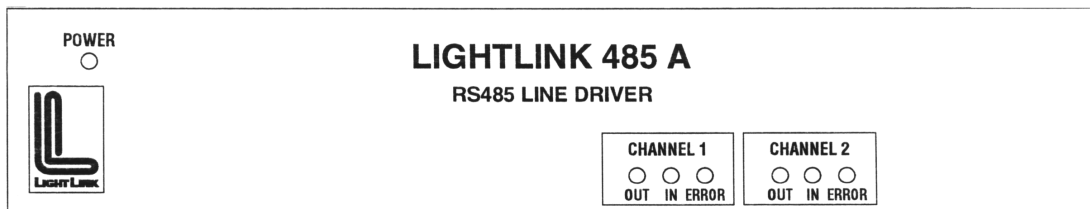

3.2 BACK PANEL

On the back panel are from left to right :

- Channel 1 optical TX Channel 2 optical TX interface
- Channel 1 optical RX Channel 2 optical RX interface
- Dipswitch for channel 1 Dipswitch for channel 2
- DB 15 connector
- Power connector

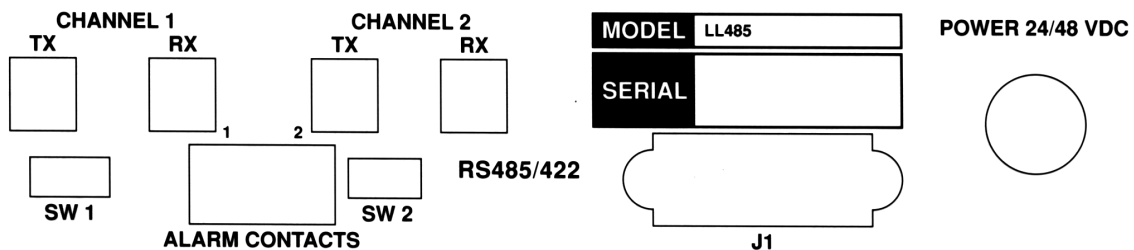

4. CONFIGURATION SETUP

4.1 DIPSWITCH CONTROLS

Dipswitch 1 controls channel 1 and dipswitch 2 controls channel 2. With the unit back towards the user, Dipswitch 1 is the on the left and Dipswitch 2 on the right.

4.1.1 DIPSWITCH 1 & 2 CONFIGURATION

DIPSWITCH 1 & 2				OPERATION
SW1	SW2	SW3	SW4	
OFF	OFF	OFF	OFF	RS422 (4 WIRE) : TRI-STATE
OFF	OFF	ON	OFF	RS422 (4 WIRE) : TX ALWAYS DRIVES ON
ON	ON	OFF	OFF	RS485 (2 WIRE) : TRI-STATE

4.2 JUMPER SETTINGS

Terminate the data lines with a 120Ω resistor by connecting or shunting the following pins on the DB15 connector :

Jumper E1 = channel 1 default inserted DB15 pin 11- 12

Jumper E2 = channel 2 default inserted DB15 pin 13 - 14

Jumpers E3 and E4 connects both channel 1 and channel 2 RX signals together. This can also be accomplished by shunting pins 1 to 2 and 9 to 10 on the DB15 connector.

Default = not inserted

4.3 DATA CONNECTION (DB 15 CONNECTOR).

PIN	SIGNAL	INPUT/OUTPUT SETUP
1	RX1+ / TX1+	IN / OUT
2	RX2+ / TX2+	IN / OUT
3	RX2+	
4	TERMINATION 2	
5	No Connection	
6	TX1+	OUT
7	TX2+	OUT
8	GND	
9	RX1- / TX1-	IN / OUT
10	RX2- / TX2-	IN / OUT
11	TERMINATION 1	
12	RX1+	
13	TX1-	OUT
14	TX2-	OUT
15	No Connection	

5. PREPARATION FOR USE

1. Set Dipswitch settings - (SW1 on for 2 wire RS 485 OPERATION)
2. Set jumpers. (termination if required)
3. Connect an optical fibre between optical transmit on local unit to optical receive on remote unit. Connect an optical fibre between optical receive a local unit to optical transmit on remote unit.
4. Connect power to the local and remote RS485A units. The power light should light up when power is applied.
5. The two channels on the unit (channel 1 and channel 2) are independent of each other and are identical in operation. Channel 1 on the local unit can work to channel 1 or channel 2 on the remote channel, and channel 2 on the local unit to channel 1 or channel 2 on the remote unit.
6. If both channel 1 and channel 2 are used in the 2 wire configuration and connected together then take care not to put the termination resistor on both channels as the effective termination resistance with both inserted will then be 60 Ohms.

5.1 TYPICAL APPLICATIONS

5.1.1 RS485 2 wire configuration:

1. Set dipswitch 1 on (for RS485 transmission)
2. Connect Copper data to DB15 connector.

If using channel 1:

Data + to DB15 pin 1

Data - to DB15 pin 9

Connect a fibre from the optic TX port (channel 1) to a remote unit's RX port.

Connect a fibre from the optic RX port (channel 1) to a remote unit's TX port.

Insert the termination resistor if unit is situated at the end of a line.

If using channel 2:

Data + to DB15 pin 2

Data - to DB15 pin 10

Connect a fibre from the optic TX port (channel 2) to a remote unit's RX port.

Connect a fibre from the optic RX port (channel 2) to a remote unit's TX port.

Insert the termination resistor if unit is situated at the end of a line.

5.1.2 RS485 4 wire configuration:

1. Set dipswitch 1 off .
2. Connect Copper data to DB15 connector.

If using channel 1:

Data RX+ (data into unit) to DB15 pin 1

Data RX- (data into unit) to DB15 pin 9

Data TX+ (data from unit) to DB15 pin 6

Data TX- (data from unit) to DB15 pin 13

connect a fibre from the optic TX port (channel 1) to a remote unit's RX port.

connect a fibre from the optic RX port (channel 1) to a remote unit's TX port.

Insert the termination resistor if unit is situated at the end of a line.

If using channel 2:

Data RX+ (data into unit) to DB15 pin 2

Data RX- (data into unit) to DB15 pin 10

Data TX+ (data from unit) to DB15 pin 7

Data TX- (data from unit) to DB15 pin 14

connect a fibre from the optic TX port (channel 1) to a remote unit's RX port.

connect a fibre from the optic RX port (channel 1) to a remote unit's TX port.

Insert the termination resistor if unit is situated at the end of a line.

6. PHYSICAL AND ELECTRICAL SPECIFICATION

6.1 ELECTRICAL

- Power supply:
- 115/230VAC 50/60Hz. 5Watt.
 - 48VDC. 5Watt. +/- 15% variation.
- Data:
- RS485 or RS422 DC to 500 KBaud
 - Data sampled at 4 MBaud
 - 2 wire or 4 wire
- Connection:
- 15 pin "D" subminiature female.

6.2 OPTICAL

- Connectors:
- SMA Multimode
 - ST Multimode / Singlemode
- Fibre Compatibility:
- Multi-mode 50 - 100 micron.
 - Single-mode 9 micron.

6.3 FUNCTIONS AND CHARACTERISTICS

- Indicators:
- Power
 - Channel1: Data in, Data out, optical input error
 - Channel2: Data in, Data out, optical input error
- Physical:
- Depth: 180mm Height: 42mm
 - Width: 202mm Weight: 1.5Kg
- Environmental conditions:
- Temperature: 0-40C
 - Humidity: 0-95% non-condensing.

7. MODEL NUMBERS

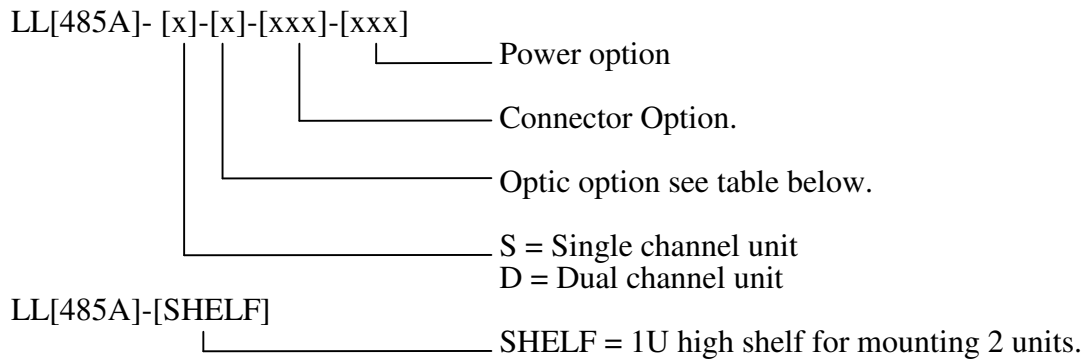

OPTIC OPTION

Stock Code	Optic Option	Connector Option	Wavelength	Fibre Mode	Power Budget	Budget Distance
A	850sr	ST or SMA	850nm	Multi-mode	10dB	3,5Km
B	1300mr	ST or SMA	1300nm	Multi-mode	10dB	12Km
C	1300mrs m	ST or FC	1300nm	Multi-mode Single-mode	15dB 12dB	16Km 16Km
D	1300lr	ST or FC	1300nm	Multi-mode Single-mode	28dB 25dB	28Km 50Km
E	1300laser	ST or FC	1300nm	Multi-mode Single-mode	36dB 35dB	36Km 70Km

OPTIC CONNECTOR OPTION

Stock Code	Connector
A	SMA
B	ST
C	FC

POWER SUPPLY OPTION

Stock Code	Power Supply
A	220 VAC
B	110 VAC
C	48 VDC
D	24 VDC
E	220/110 VAC

