

PRODUCT – OS304M
 Four Channel Fibre Optic MUX.
 USER MANUAL
 VERSION 'F'
 16th July 2004

Product: OS304M		Model:	
Serial Number:		JOB No :	
TEST	CRITERIA	RESULT	
Power Supply Input Voltage			
Power Supply Output Voltages	+5V, +12V, -12V, +80V, -48V		
Master Oscillator Frequency (P7)	16,384MHz ± 25ppm (±400Hz)	Hz	
PLL VCXO Centre Frequency (U1 pin 77)	16,384MHz ± 50ppm (±800Hz)	Hz	
Fit Microprocessor, Eprom, and FPGA Devices. Check Power Up & Programming Sequence.			
Ring Signal (Conn 1 pin 19)	17Hz @ ± 2.0Vrms	Vrms	
Meter Signal (Conn 1 pin 20)	16kHz @ ± 1.0Vrms	Vrms	
PLL Control Voltage (P9)	2.5Vdc @ 16,384MHz	Vdc	
LED Indicators	Functional		
Alarm Contact	Optic Fail & Power Fail		
Exchange Ring Detect Ch 1 - 4	42Vrms min		
Exchange Line Looping Ch 1 - 4	Functional		
Exchange 16kHz Detection Ch 1 - 4	200mVpp min		
Tel Ring Line Voltage Ch 1 - 4	65Vrms min		
Tel Line Loop Current Ch 1 - 4	24mA		
Tel 16kHz Signalling Ch 1 - 4	± 2Vrms		
Pulse Dialling Test Ch 1 - 4	Make-To-Break Ratio Ok.		
Audio Signal Tx Level Ch 1 - 4	0dBm ± 0.2dBm		
Audio Signal Rx Level Ch 1 - 4	0dBm ± 0.2dBm		
E & M Signalling Ch 1 - 4	Functional		
iPhone Master Call + Audio Ch1 - 4	Functional		
iPhone Slave Call + Audio Ch1 - 4	Functional		
iPhone All Call + Audio Ch1 - 4	Functional		
B.E.R. < 10e-9	No Bit Errors In 8 Minutes.		
Optical Transmit Level	- dBm	-	dBm
Optical Receive Sensitivity	- dBm	-	dBm
Optical Power Budget	dB		

Date:

Tested By:

Copyright.

The information contained herein is the property of Advanced Digital Devices c.c. and may not be copied, used or disclosed in whole or in part except with the prior written permission from same.

Disclaimer.

Whereas we took great care in preparing this document Advanced Digital Devices c.c. cannot be held responsible for any errors contained herein and reserve the right to change such information without notice. Although we take great care in producing the equipment, Advanced Digital Devices c.c. assumes no responsibility for any claim which may arise through the use of the equipment.

1.0 PRODUCT DESCRIPTION

1.1 GENERAL

The OS304M is a 4-channel 64kbps audio drop-and-insert multiplexer. The OS304M forms part of a telecommunication system operating in a ring network. The ring is controlled from a master unit - named the OS2030. The OS2030 is designed to transmit a 2 Mbps CCITT G703 data link over fibre. This unit interfaces between G704 CAS protocol and several OS304MUX units. The OS304MUX unit can then drive a number of different interface modules that are simply plugged into the unit, and set up accordingly via a management software solution.

The OS304M can also operate in a Master mode, allowing a point-to-point operation with another OS304M, or a simpler ring network consisting of only OS304M muxes.

The unit has a built-in 4 port bus system which can house any combination of line terminating equipment modules. At present only the following is available :-

Exchange Module - stock code 'OS301E'.

This interfaces directly with an exchange line, or PABX line, and simulates the functions of a telephone.

Telephone Module - stock code 'OS301T'.

This unit can couple directly to a telephone instrument and simulates the functions of an exchange.

4W Audio E & M Module - stock code 'OS301W'.

This is a 2-wire or 4-wire audio interface with E & M signalling.

iPhone Module - stock code 'OS301AM' (Master) and 'OS301AS' (Slave).

This is an iPhone Intercom System interface module.

The OS304M can be configured by software to accept any of the above line terminating modules. To configure the OS304M, a PC with dedicated management software is required. The configuration can be downloaded directly into the unit by using its internal RS232 port. Or it can be downloaded to the OS2030 master unit, that will in turn forward the configuration to the OS304M via the supervisory channel across the fibre link. New software can also be downloaded in this way, or can be installed using pre-programmed E²PROM's which are available from the supplier.

The unit is modular in design and can thus be upgraded with different optics or power supply options. The distance over which the system can operate is determined by the fibre interface used. The options are limited to 3, 12, 18, 26, 36, 52 and 90 Kilometres. The power supply can be replaced by removing the power supply module and fitting the required module. Either 220VAC, 110VAC, 48VDC or 12VDC. Other voltages can also be supplied on request.

The system uses the latest technology in line driving and decoding integrated circuits and therefore complies fully with the stringent CCITT standards. The unit comes in two options. The first is housed in a small metal enclosure compact enough to fit two next to each other in a 19" rack with a height of 2U. The second consists of a rack mount card that can plug directly into an OS800 3U 19" sub rack.

The unit has a built in framer. The framer will take the received data and re-time the data for transmission further down the line. Whenever a timeslot allocated to a particular outstation is reached, the time slot will be dropped off to the correct line interface and the interface data is then inserted in the frame.

Line interface.

The line interface will consist of a CODEC that is programmed by the intelligent processor unit.

The CODEC will be programmable and will control the following :-

- Transmit Gain - adjustable over a 10dB scale in steps of 0,1dB. Max gain is 6.9dB.
- Receive Gain - adjustable over a 10dB scale in steps of 0,1dB. Min sensitivity is -18dB
- Adjustable Hybrid Balance registers.

A Dip switch setting will identify the location of the OS304M .

Note that the dip switch number 4 will select between Master and Slave in a point to point system.

The system operates over a single Fibre ring. The optical interface can be interchanged to suit the application.

Ring connection

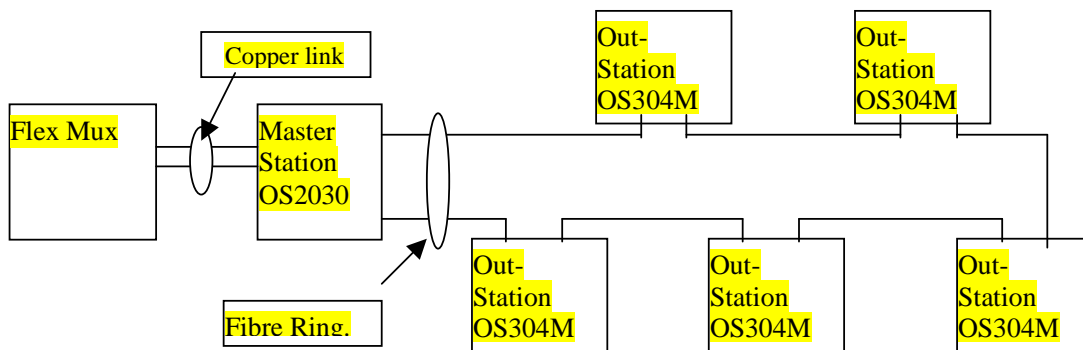

Point to Point

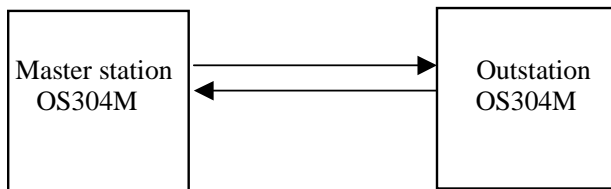

Dipswitch4 ON

1.2 ALARMS AND INDICATIONS

ALARMS AND INDICATIONS.

Power indication

Indicates power to the processor.

Indicates optic receive data valid.

Ring and loop

Each channel has a ring and loop indication mimicking the signalling to that channel.

DIP SWITCH SETTINGS.

Dip switches 1 to 3 selects the multiplexer address or number in the ring network. Note that switch position 0 relates to outstation 1 and is all switches off. The switches reads in a binary code. Dip switch 1 'on' is outstation 2, and so on.

SW1	SW2	SW3	SW4	Outstation
Off	Off	Off	Off	Nbr 1.
On	Off	Off	Off	Nbr 2.
Off	On	Off	Off	Nbr 3.
On	On	Off	Off	Nbr 4.
Off	Off	On	Off	Nbr 5.
On	Off	On	Off	Nbr 6.
Off	On	On	Off	Nbr 7.
On	On	On	Off	Nbr 8.
X	X	X	On	Master

Dip switch 4 is used only in a point-to-point connection and will identify which unit is assumed to be the Master.

MANAGEMENT FACILITIES

The unit is equipped with a internal RS232 connector which enables the unit to be configured. A dedicated software package (OS2030) that runs under windows allows setting up of time slots and interface options.

If the configuration is known at the time of manufacture the units can be delivered pre configured. Alternatively it is necessary to configure the system before it can be operated. Special configuration facilities can be accessed using the software package on a portable computer.

The software allows the following facilities.

Uploading and Downloading of software on the OS2030.

Should it be required new software for the OS304M unit can be downloaded. The user can choose which software must be downloaded. Once downloaded the unit must be reset for the software to be become active. This is done automatically in a properly installed system.

Setting up of channel configurations.

The software also allows setting up of line configurations and gain adjustments for each time slot. Once the alterations are done it must be downloaded. The alterations will take effect after a short delay. A Backup copy of the configuration for a particular system should be stored on the system disk.

SPARE PART CODES

This unit must be ordered by using the following Order Number Selection table.
 Replace the 'X', in the left hand column, with the appropriate option selected to get the correct Order Number for the equipment required.

X	U	Universal 85-250Vac/110-220Vdc PSU	Power Supply Option
	I	12Vdc PSU	
	G	24Vac PSU	
	F	110VDC PSU	
	E	220/110 Vac PSU	
	D	24Vdc PSU	
	C	48Vdc PSU	
	B	110Vac PSU	
	A	220Vac PSU	
X	C	FC/PC Optic Connection	Optic Connector Option
	B	ST Optic Connection	
	A	SMA Optic Connection	
X	C	1300nm Optic Wavelength, Single mode	Optic Wavelength Option
	B	1300nm Optic Wavelength, Multi mode	
	A	850nm Optic Wavelength, Multi mode	
304M	4 Channel Fibre Optic Mux		
OS	Optic Solutions		

Define stock code and add spare part code in second character position.

OX304MXXX /X

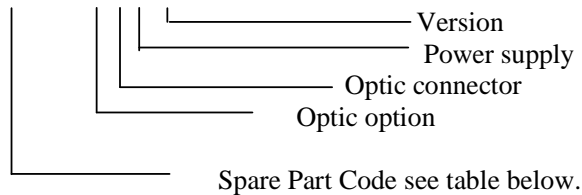

SPARE PART OPTION

Spare Part Code	Description
A	POWER SUPPLY CARD
B	PROCESSOR CARD
C	OPTIC CARD
E	METAL BOX COMPLETE
F	POWER CABLE

Additional Spare parts.

Stock Code	Description
OS301E	Line Interface unit for Exchange
OS301T	Line Interface unit for Telephone
OS301W	Line Interface unit for 4W Audio E & M
OS301AM	AiPhone Interface, Master Side
OS301AS	AiPhone Interface, Slave Side

3.0 PREPARATION FOR USE

3.1 UNPACKING

Check for physical damage caused during transport. Return any damaged equipment.
Remove packaging material.

3.2 INSTALLATION

See connection diagram annexure 'A4'.

Check the Voltage supply rating of the equipment before installation commences.

Ensure that the link loss over the fibre cable is within the power budget of the equipment. See the model number and optic option.

When installing the unit in a 19" rack the feet of the unit must be removed in order for it to fit in a 1U high space. A shelf is supplied as a separate item, which supports two units next to each other.

Connect the chassis earth leads to the shelf. Connect the common earth to the shelf. This is very important. Ensure that all equipment is properly earthed.

Secure the unit by installing the 'screw on bracket' at the rear of the unit.

Connect the Line and optic cables. The Optic link must be connected local transmit to remote receive and visa versa.

It is necessary to observe the modules with which the unit is equipped and to connect the circuits according to the attached diagrams. Should it be necessary to change the line interface the unit must be opened. Ensure that the unit is powered down before opening. Then carefully replace the line interface module with the required unit. Then also mark the appropriate line on the back panel with the correct designation.

When circuits are used that are exposed to lightning and other EMI interference these lines must have additional protection.

It is very important to earth the system properly to protect against any interference.

If the alarm extension is required then connect the extension wire to the voltage free alarm contacts at the back of the unit.

Connect the power cable.

Should the unit operate on DC power then the D.C. power connections are shown on the rear panel.

The equipment has no on/off switch thus it will be active as soon as the power is connected.

3.3 COMMISSIONING

At switch on the unit will flash the Ring and loop indications while performing a software load and verification procedure. If the link is correctly connected the 'Link OK' indication will light up.

4.0 OPERATORS INSTRUCTIONS

The unit need no operator intervention to function, however when a fault arises, it is necessary to observe the alarm indications.

See maintenance instructions for any other functions.

5.0 MAINTENANCE INSTRUCTIONS

5.1 INSTRUMENTS AND TOOLS REQUIRED

Multimeter

Optic power meter

5.2 FIRST LINE MAINTENANCE

When arriving at a suspect link it is necessary to note the alarm condition of the equipment.

First observe the power indication. If the power indicator is off then check the power supply. The AC unit has a fuse inside the connector at the rear and an additional fuse inside the unit. The DC unit has a fuse inside the unit. If necessary replace it with the correct value fuse.

Next observe the alarm conditions.

'Link OK'

If this led fails to operate then the Fibre optic input signal has failed.

Measure the receive optic power using the Optic power meter. A Level of $> -28\text{dB}$ at 1300nm must be measured.

'Ring and loop indications'

If in addition to the Link OK indication being off a ring or loop indication remains on then it indicates corrupted software in the unit and new software must be downloaded to the unit. See the management manual 'OS2030M' on downloading of software.

PHYSICAL AND ELECTRICAL SPECIFICATION

ELECTRICAL

Power supply:

115/230VAC 50/60Hz. 15Watt.
-48VDC. 15Watt.

Impedance:

600 ohms on all circuits
Frequency response 300 to 3400Hz

Tel line parameters:

Line current : 24mA
Line ringing Voltage 55VRMS 17Hz
Meter signal: 200mV RMS
Max loop resistance 1500 ohms

Connection:

RJ11 6 pin

- E
- Receive Audio a leg
- Transmit Audio a leg, Tel a leg
- Transmit Audio b leg, Tel b leg
- Receive Audio a leg
- M

OPTICAL

Connectors:

FCPC/ST Multi-mode/Single-mode
Fibre Compatibility
Multi-mode 50/125 micron.
Single-mode 9/125 micron.

FUNCTIONS

Indicators.

Power,
LinkOK,
Ring, loop for all channels.

Alarm Output.

Voltage free alarm output contact.

PHYSICAL

Depth: 180mm Height: 42mm
Width: 202mm Weight: 1.5Kg

ENVIRONMENTAL CONDITIONS

Temperature: -5°C to +45°C
Humidity: 0-95% non-condensing.

ANNEXURE A1 GRAPHIC ILLUSTRATION OF DATA FLOW.

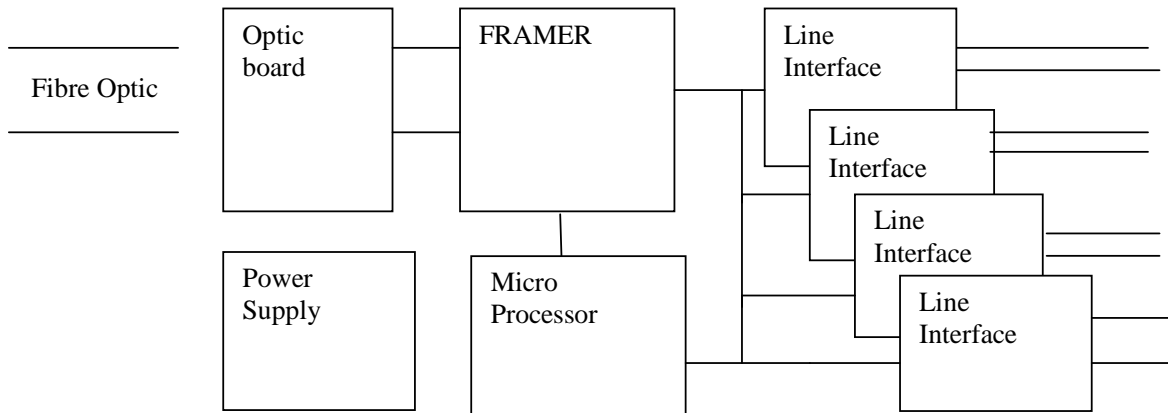

ANNEXURE A2 FRONT PANEL.

Enclosure:

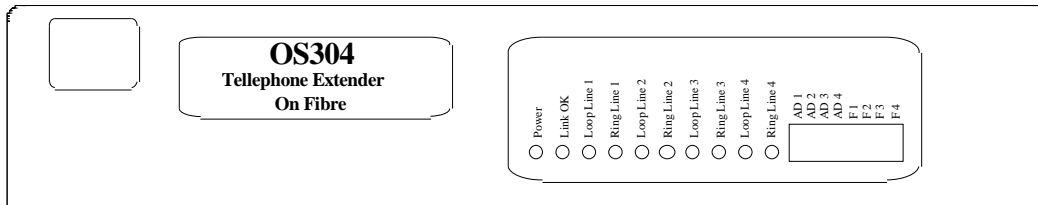

Rack:

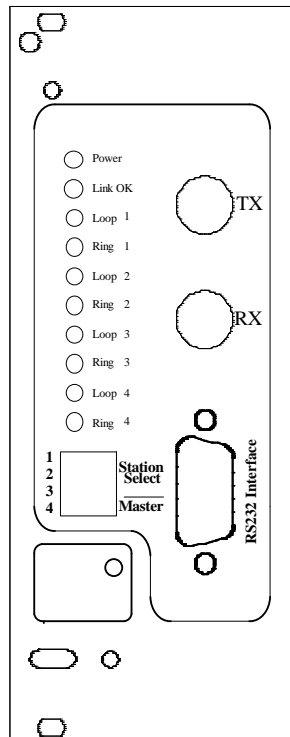

ANNEXURE A3 REAR PANEL.

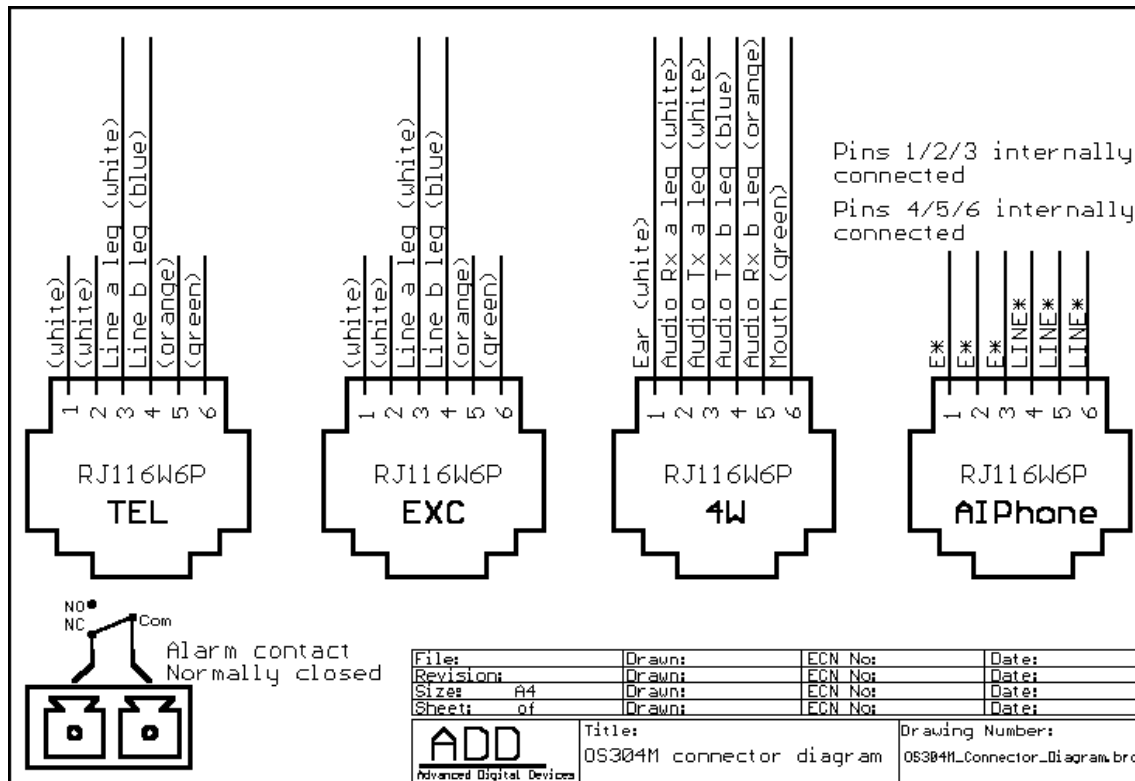
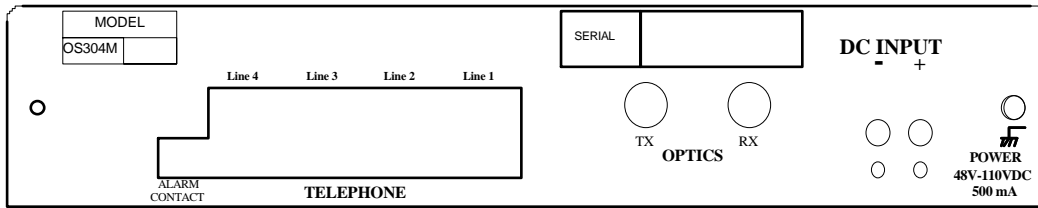
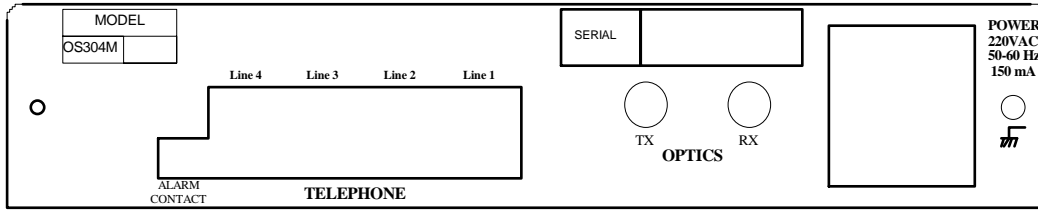

ANNEXURE A4 CONNECTION DIAGRAM. (BOX MOUNT then RACK MOUNT)

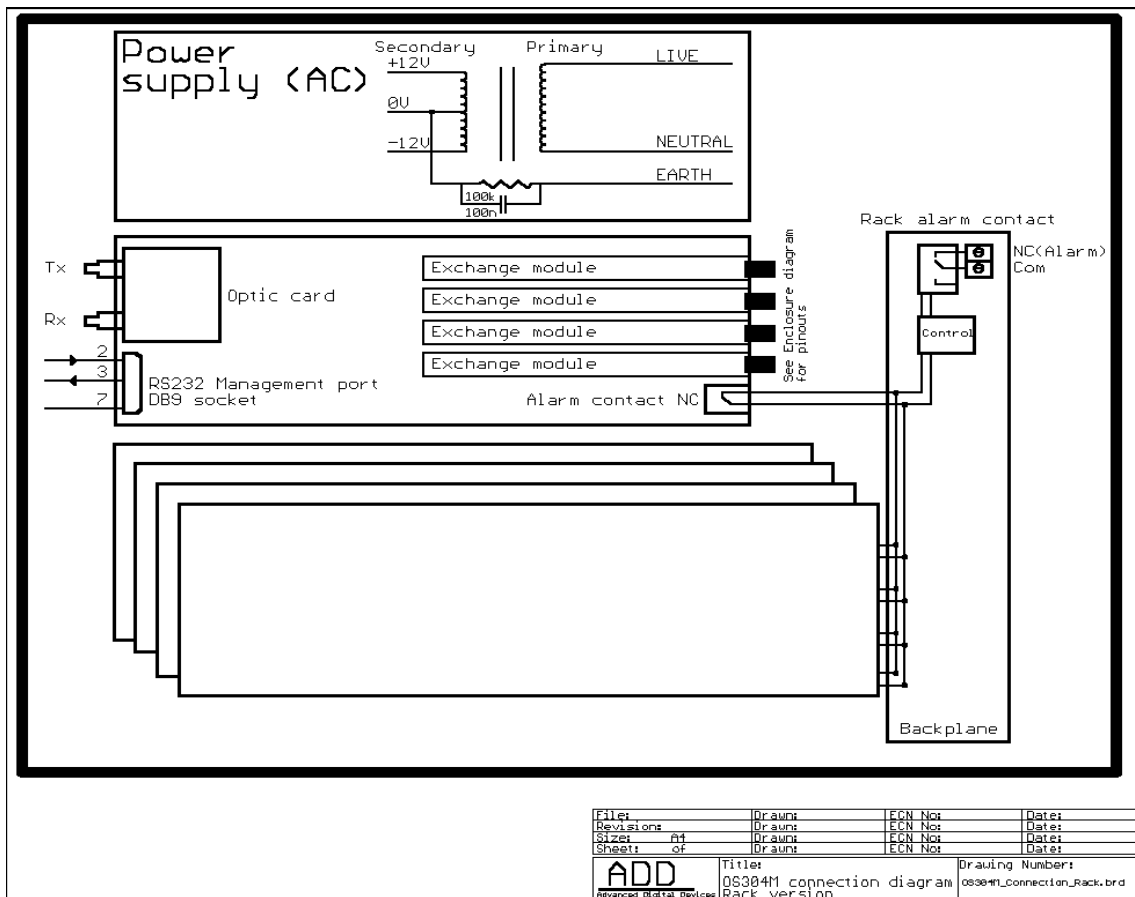
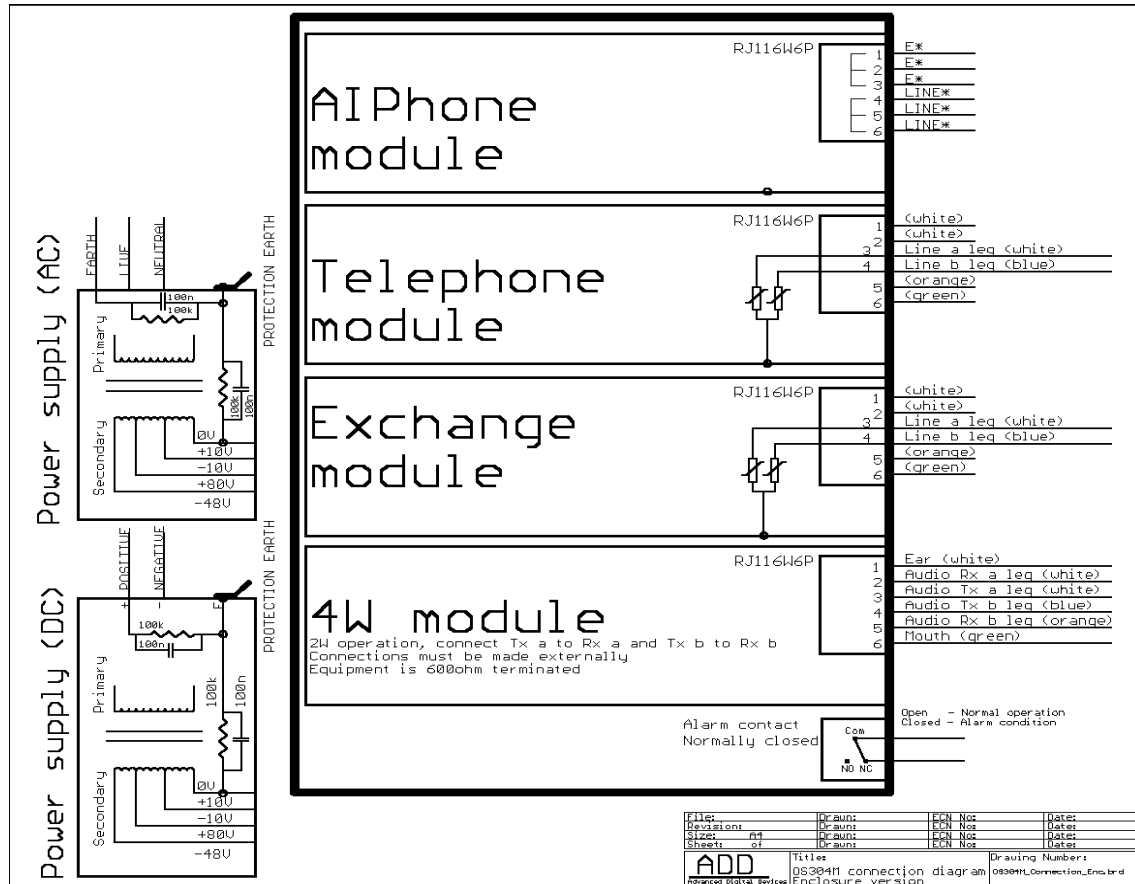

ANNEXURE A5 PCB LAYOUT.

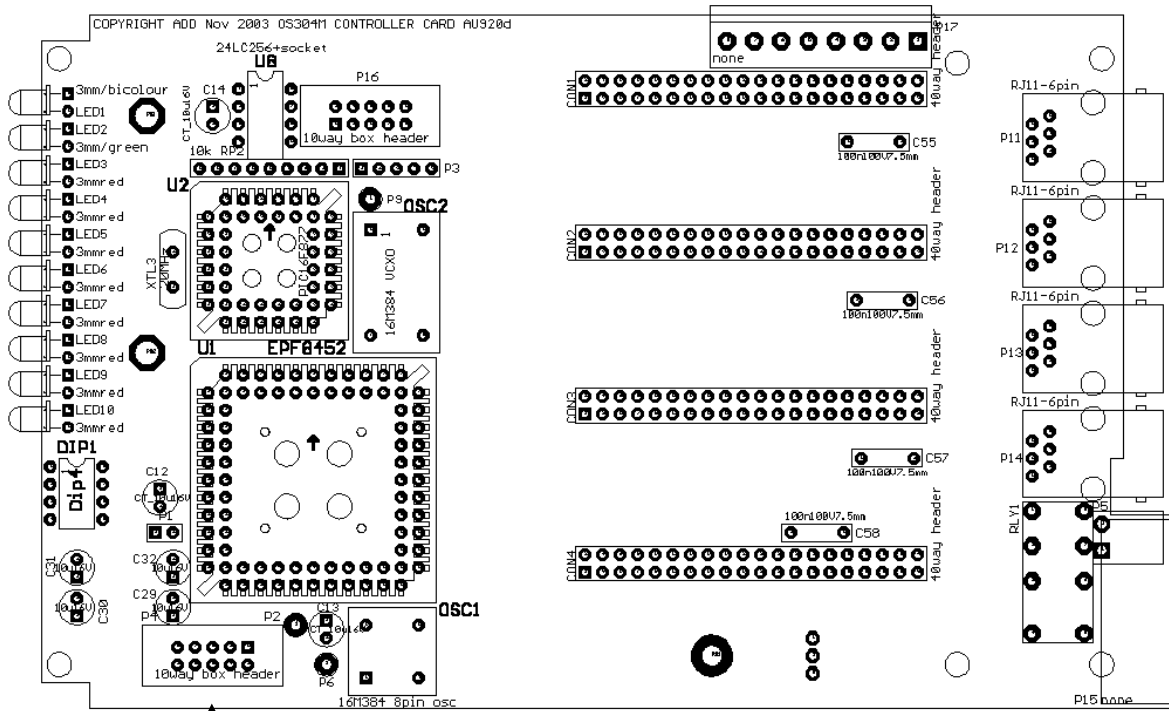

RS232 connector

