

PRODUCT – LL304E/T  
 Four Channel Telephone Line  
 Extender On Fibre System  
 USER MANUAL  
 08 November 2004

<b>Product: LL304</b>		<b>Model:</b>			
<b>Serial Number:</b>		<b>Job No:</b>			
<b>TEST</b>		<b>CRITERIA</b>		<b>RESULT</b>	
Power Supply Output Voltages		+5V, +12V, -12V			
High Voltages For Telephone Side		+80V, -48V			
Master Oscillator Frequency		16,384MHz ± 12ppm (±200Hz)		Hz	
PLL VCXO Centre Frequency		16,384MHz ± 25ppm (±400Hz)		Hz	
Fit Microprocessor and FPGA Devices. Download software. Check Power Up & Programming Sequence.					
Ring Signal		17Hz @ ± 2.0Vrms		Vrms	
Meter Signal		16kHz @ ± 1.0Vrms		Vrms	
PLL Control Voltage		2.5Vdc @ 16,384MHz		Vdc	
LED Indicators		Functional			
Exchange Ring Detect	Ch 1 - 4	42Vrms min			
Exchange Line Looping	Ch 1 - 4	Functional			
Exchange 16kHz Detection	Ch 1 - 4	200mVpp min			
Tel Ring Line Voltage	Ch 1 - 4	65Vrms min			
Tel Line Loop Current	Ch 1 - 4	24mA			
Tel 16kHz Signalling	Ch 1 - 4	± 2Vrms			
Pulse Dialling Test	Ch 1 - 4	Make-To-Break Ratio Ok.			
Optical Transmit Level		- dBm		- dBm	
Optical Receive Sensitivity		- dBm		- dBm	
Optical Power Budget		dB			

**Tested By :** .....

**Date :** .....

**Copyright**

The information contained herein is the property of Advanced Digital Devices cc, and may not be used, copied or disclosed, in whole, or in part, except with the prior written permission from same.

**Disclaimer**

Whereas we took great care in preparing this document, Advanced Digital Devices cc cannot be held responsible for any errors contained herein, and reserve the right to change such information without notice. Although we take great care in producing the equipment, Advanced Digital Devices cc assumes no responsibility for any claim that may arise through the use of the equipment.

## TABLE OF CONTENTS

1	PRODUCT DESCRIPTION.....	3
1.1	General.....	3
1.2	Basic System Description .....	3
2	STOCK CODES .....	4
3	PREPARATION FOR USE .....	5
3.1	Unpacking .....	5
3.2	Configuration & Installation .....	5
4	OPERATOR'S INSTRUCTIONS.....	5
5	MAINTENACE INSTRUCTIONS .....	6
5.1	First Line Maintenance .....	6
5.1.1	Instruments & Tools Required .....	6
5.1.2	First Line Maintenance .....	6
6	SPECIFICATIONS .....	7
6.1	Electrical .....	7
6.2	Physical.....	7
6.2.1	Desktop Unit.....	7
6.2.2	Rack-Mount Unit.....	7
6.3	Environmental .....	7
7	WIRING BLOCK DIAGRAM.....	8
8	CONTACT DETAILS .....	8

## 1 PRODUCT DESCRIPTION

### 1.1 General

The LL304E/T is a 4-channel telephone line extender on fibre system. The LL304E is the Exchange side unit that interfaces directly to incoming telephone lines, or to a PABX, and resembles the standard telephone instrument characteristics. The LL304T is the Telephone side unit that interfaces directly to telephone instruments and resembles the standard exchange characteristics.

### 1.2 Basic System Description

The LL304E acts as the Master unit that generates the system clock, and the LL304T acts as a Slave unit that locks onto the Master unit. The LL304E unit digitises the four telephone lines and multiplexes them into a single high-speed data stream, which is then converted into an optical signal for transmission across optical fibre. The LL304T unit converts the optical signal received from the fibre into a high-speed data stream, which is then demultiplexed and converted into the four separate analogue telephone lines again. The same process happens in the opposite direction.

The LL304E units are available in two options. The first is a standalone desktop unit in a small metal enclosure that is compact enough so that two units can fit side by side in a 19" rack, with a height of 2U. The second is a rack mount card that can plug directly into an OS800 3U 19" sub rack assembly. The LL304T can only be supplied as a standalone desktop unit.

The unit is modular in design and can thus be upgraded easily with different power supplies or optic options. The power supply options available are 220Vac, 110Vac, 110Vdc, 48Vdc and 12Vdc. The optic options cover distances of 3.5 & 12km on multimode, and up to 40 or 80km on singlemode.

#### Features

- Sends four analogue telephone lines across a single fibre pair
- Noise and EMI immunity as compared to long copper cable runs
- Modular design allows quick & easy changing of power supplies and optic options

#### Indications

The unit has 10 Led's which indicate the following:

**Power** Indicates that the unit is powered

**LinkOK** Indicates that the unit is locked to the remote unit.

<u>Channel</u>	<u>Exchange side</u>	<u>Telephone side</u>
1	<b>Loop1</b> Exchange line looped <b>Ring1</b> Exchange is ringing	<b>Loop1</b> Phone picked up <b>Ring1</b> Phone ringing
2	<b>Loop2</b> Exchange line looped <b>Ring2</b> Exchange is ringing	<b>Loop2</b> Phone picked up <b>Ring2</b> Phone ringing
3	<b>Loop3</b> Exchange line looped <b>Ring3</b> Exchange is ringing	<b>Loop3</b> Phone picked up <b>Ring3</b> Phone ringing
4	<b>Loop4</b> Exchange line looped <b>Ring4</b> Exchange is ringing	<b>Loop4</b> Phone picked up <b>Ring4</b> Phone ringing

## 2 STOCK CODES

The stock code is made up as follows:

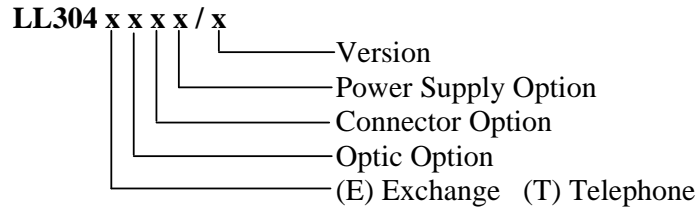

Optic Option	Fibre Type	Wavelength	TX Level	RX Sens	Optic Budget	Range*
A	Multimode	850 nm	-18dBm	-30dBm	10dB	3.5km
B	Multimode	1300 nm	-20dBm	-32dBm	10dB	12 km
C	Singlemode	1310 nm	-12dBm	-32dBm	18dB	36 km
E	Singlemode	1310 nm	-6dBm	-32dBm	26dB	52km
F	Singlemode	1310 nm	0dBm	-32dBm	32dB	63km
H	Singlemode	1550nm	-12dBm	-32dBm	20dB	80km

Connector Option	Type
A	SMA
B	ST
C	FC/PC

Power Supply Option.	Type
A	220Vac
B	110Vac
C	48Vdc
F	110Vdc
I	12Vdc

**\*N.B.** The distance given is approximate, and assumes a good fibre without any bad splices.

### 3 PREPARATION FOR USE

#### 3.1 Unpacking

Each unit is shipped factory tested, and carefully packed in a protective packaging. Carefully unpack the units and visually inspect them for any damage that may have occurred during transport. The manufacturer will not be held liable for any damage during transport.

#### 3.2 Configuration & Installation

Check that the supply voltage matches that of the equipment before the installation commences. Also ensure that the total link loss across the fibre falls within the optical power budget of the equipment. See the Stock Codes for the different options and specifications.

Begin by connecting the power cables to the unit. The units have no power switch and will be ON the moment the power is connected. The connector will be a 3-pin power socket for AC units, or a 2-pin screw terminal for DC units. Take note that the power indication on the front panel is lit. Proceed to connect the fibre cables, taking note that TX on the local side must be connected to RX on the remote side; and vice versa. Be careful not to contaminate the fibre ends, or to bend the fibre beyond its tolerances. Once both directions are linked, the LINKOK led's should light up on both sides.

On the exchange side, the cables can now be connected between the PABX and the Exchange unit. On the telephone side, the telephone instruments can be plugged directly into the Telephone unit. The centre two pins (3 & 4) of the RJ11 connector are used to connect to the telephone lines, and are not polarized.

Finally, connect the Protection Earth tag on the back of the unit to a known good Earth point (such as an Earth Bus Bar). This is essential for the protection circuits inside the unit. It is also recommended to add additional Lightning Gas Arrestors to the incoming telephone lines.

#### Basic Circuit Operation

System operation when the telephone is picked up to make a call:

- 1) LOOP (T)                    ON    - When telephone is picked up
- 2) LOOP (E)                    ON    - The Exchange unit loops the exchange line

System operation when the Exchange rings a telephone:

- 1) RING (E)    FLASHING - The exchange is ringing the line
- 2) RING (T)    FLASHING - The Telephone unit is ringing the telephone
- 3) LOOP (T)                    ON    - The telephone has been picked up
- 4) LOOP (E)                    ON    - The Exchange unit loops the exchange line
- 5) RING (E) & (T)    OFF   - The Ringing process stops.

### 4 OPERATOR'S INSTRUCTIONS

The unit needs no operator intervention to function correctly. If a fault arises, it is necessary to observe the indicators on the front panel and to perform such procedures as outlined in the maintenance instructions.

## **5 MAINTENACE INSTRUCTIONS**

No routine maintenance is required on this equipment.

### **5.1 First Line Maintenance**

#### **5.1.1 Instruments & Tools Required**

- Multimeter
- Optic Power Meter
- Telephone Test set

#### **5.1.2 First Line Maintenance**

When arriving at a suspect link, it is always necessary to observe the indications and to ensure that all the copper connections have been done correctly. Many faults are sometimes traced to broken or shorted wires, especially in industrial environments.

First observe the POWER indicator. If it is OFF, use the multimeter to check the supply voltage. Next, the fuses must be checked. The AC unit has a fuse inside the power socket at the back of the unit. The DC unit has a fuse inside on the power supply board itself. Replace any blown fuses only with those of the same value. If the fuse blows again, then the power supply is faulty and the unit will have to be sent for repair.

Next, observe the LINK OK indicator. If it is OFF then it means the unit is unable to lock onto a signal from the fibre. Use the Optic Power Meter to measure the strength of the incoming signal on the RX fibre. The unit will fail to lock if this level falls outside of the specification. If there is no reading, then either the fibre is faulty or the remote unit is not transmitting, and will have to be checked.

Next, use the Optic Power Meter to measure the Optic Transmit Level and ensure that it is within the specification. If this level is very low, then the remote unit might not lock onto it. If all the POWER and LINK OK indications are ON, then all the lines must be tested for functionality with a Telephone Test Set.

If all these tests have been done, and the units are still not operational, then the supplier should be contacted, and the units possibly sent in for repair.

## 6 SPECIFICATIONS

### 6.1 Electrical

<b>Power Consumption:</b>	~ 30mA @ 220Vac	6.6W
	~100mA @ 48Vdc	4.8W
	~ 55mA @ 110Vdc	6.1W
<b>Telephone Line:</b>		
Line Impedance	600 Ohm	
Frequency Response	300Hz to 3400Hz	
Line Loop Current	24mA (or 30mA; as requested)	
Line Voltage	>36Vdc	
Ring Detection	42Vrms min	
Line Ring Voltage	55Vrms min	
16kHz Detection	200mVp-p min	
16kHz Signalling	± 2Vrms	
Maximum Loop Resistance	1500 Ohms	

### 6.2 Physical

#### 6.2.1 Desktop Unit

Length	202mm
Width	180mm
Height	42mm (1U)
Weight	1.5kg

#### 6.2.2 Rack-Mount Unit

Euro-sized card for mounting in 3U high 19" Rack.

### 6.3 Environmental

Temperature	-5°C to +55°C
Humidity	0 - 95% non-condensating

## 7 WIRING BLOCK DIAGRAM.

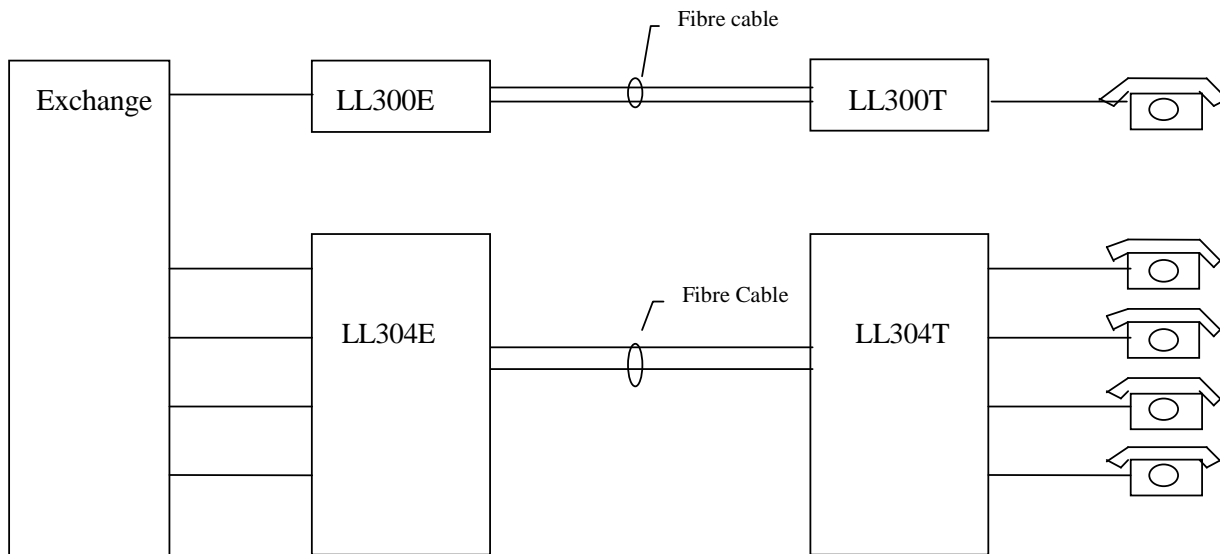

## 8 CONTACT DETAILS

Email: [support@addvid.co.za](mailto:support@addvid.co.za)

Web: [www.addvid.co.za](http://www.addvid.co.za)

**Advanced Digital Devices cc**  
**Unit 17 Bond Street Business Park**  
**cnr Bond & Kent Streets**  
**Randburg**  
**Johannesburg**  
**South Africa**  
**2125**

**P O Box 2549**  
**Randburg, 2125**  
**Johannesburg**  
**South Africa**

**Tel: +27 11 789 4420**

**Fax: +27 11 789 4422**